

Quick Specs	Applications	Series Components	Compatible With	Wire Size
	Automotive Fabrication Manufacturing	Retaining Heads Contact Tips Nozzles	TOUGH GUN® Robotic MIG Guns TOUGH GUN® Automatic MIG Guns Bernard® BTB Semi-Automatic MIG Guns Bernard TGX® Semi-Automatic MIG Guns Bernard Clean Air™ Fume Extraction Guns	0.023" to 1/8" (0.6 to 3.2 mm)

## TOUGH LOCK® Consumable Series

can help to reduce your consumable costs and related downtime.

**TOUGH LOCK Retaining Heads,** when mated with TOUGH LOCK Contact Tips, minimize contact tip temperature due to increased surface contact.

**TOUGH LOCK Contact Tips** are manufactured from high-quality, high-conductivity copper using a mandrel-drawn process that controls tip tolerances.

**Tregaskiss® Nozzles** Engineered to be extremely durable and long-lasting. Made of hard-drawn copper or brass, the smooth surface finish and rounded edges minimize weld spatter build-up.



**Dual Taper Technology** keeps consumables running cooler



Locking feature prevents tip and retaining head from loosening due to vibration

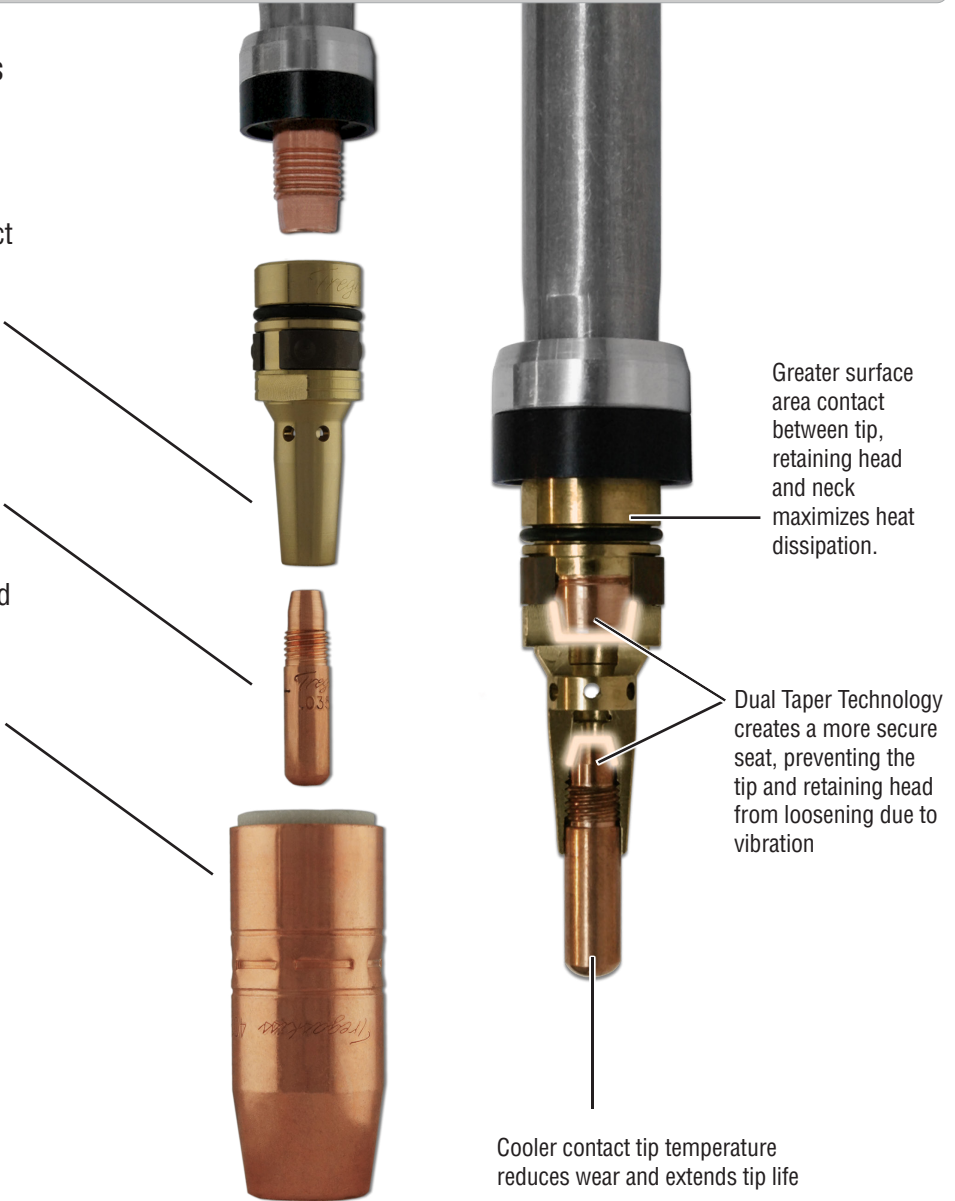

**Tregaskiss**  
2570 North Talbot Road  
Windsor, Ontario N0R 1L0  
Canada

Phone: 1-855-MIGWELD (644-9353) (US & Canada)  
+1-519-737-3000 (international)  
Fax: 519-737-1530  
For more information, visit us at [Tregaskiss.com](http://Tregaskiss.com)

# TOUGH LOCK® Consumable Series

## Standard Duty (SD) TOUGH LOCK Series

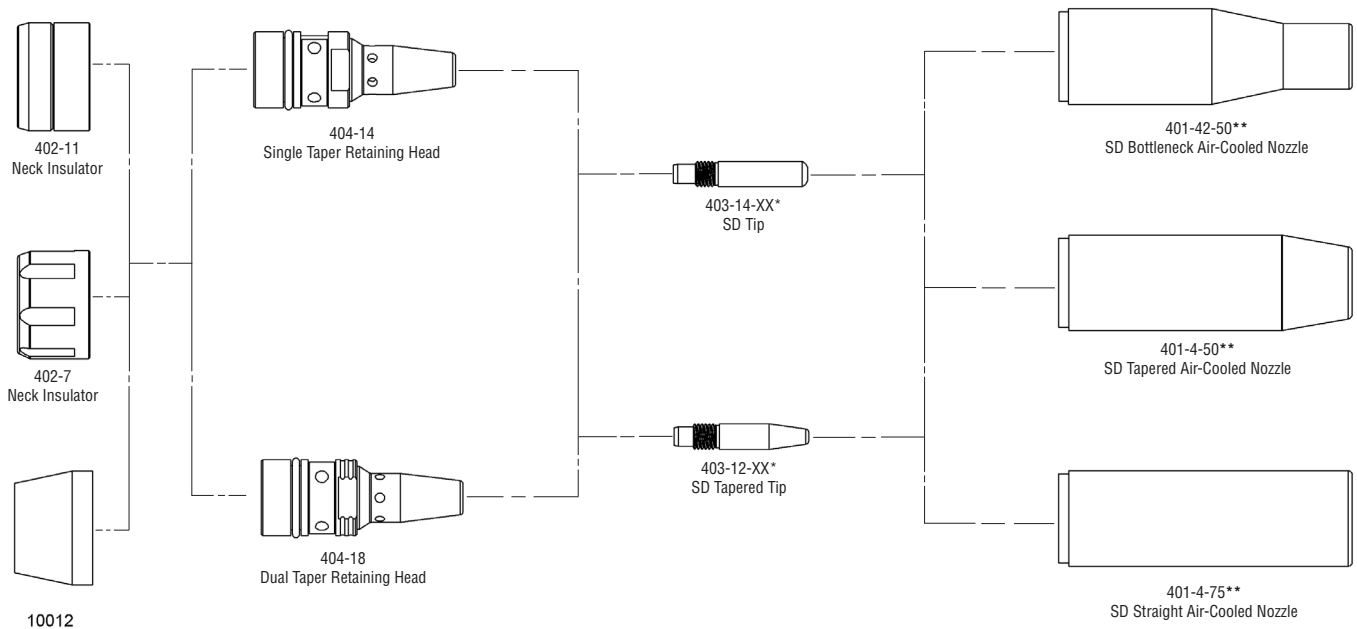

\* XX = wire size, see Contact Tip information starting on page 3

## Heavy Duty (HD) TOUGH LOCK Series

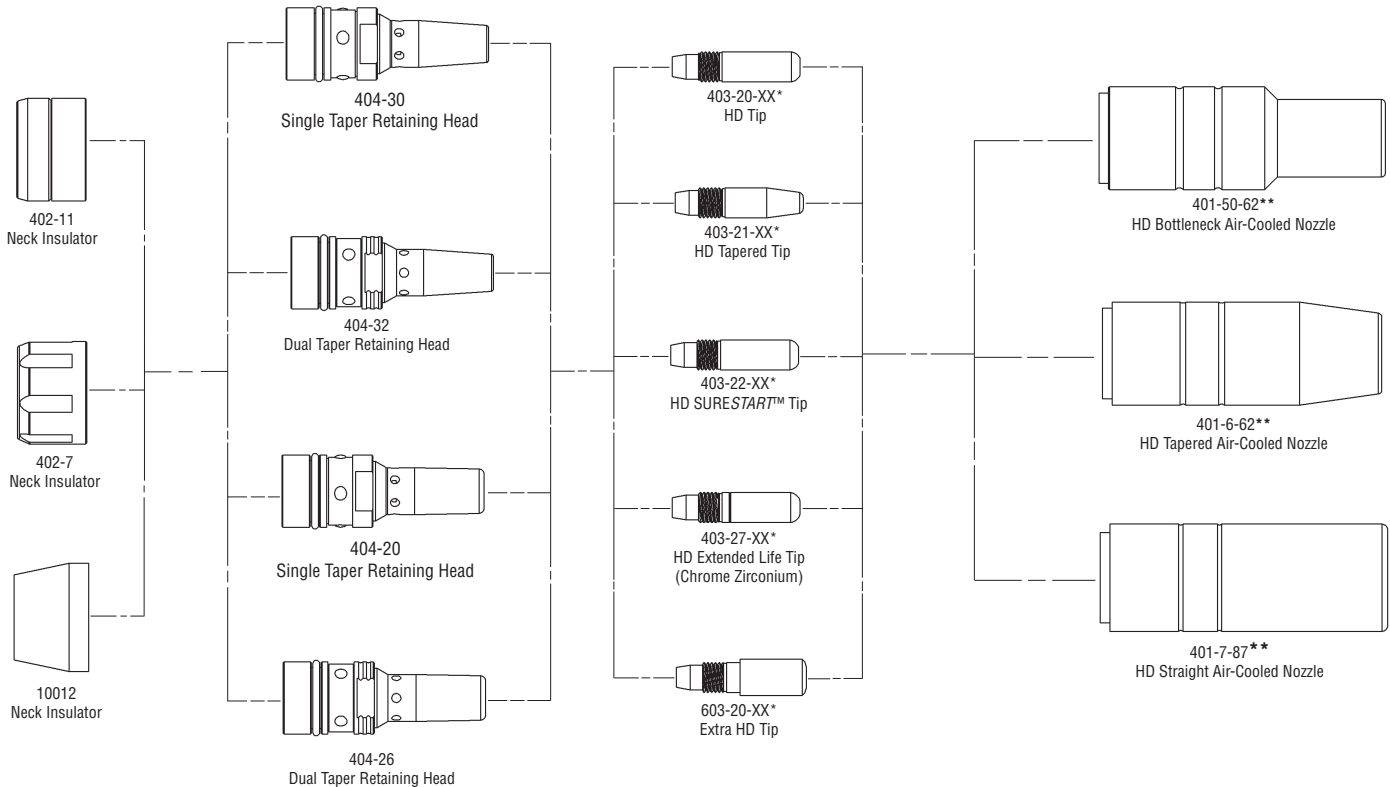

\* XX = wire size, see Contact Tip information starting on page 3

\*\*Additional nozzles are available with various stickouts, see pages 4 & 5 for options

# Retaining Heads/Diffusers

## Retaining Heads/Diffusers - For Robotic Applications

Part Number	Description	Qty	Duty	Nozzle Type	Material	Platform	Notes
404-14-25	Retaining Head	25	SD	Slip-On	Brass	A/C	Single taper SD retaining head
404-18*	Dual Taper Retaining Head	100	SD	Slip-On	Brass	A/C	Dual taper SD retaining head
404-22*	Retaining Head	100	HD	Slip-On	Brass	A/C	Single taper, set screw for liner retention
404-23-25	Retaining Head	25	HD	Slip-On	Brass	A/C	Single taper, no gas holes. Gasless Flux-Core
404-30*	Retaining Head	100	HD	Slip-On	Brass	A/C	Single taper robotic retaining head
404-32*	Dual Taper Retaining Head	100	HD	Slip-On	Brass	A/C	Standard robotic dual taper retaining head
404-36-25	Retaining Head	25	HD	Slip-On	Copper	A/C	Single taper robotic retaining head
404-52-25	Dual Taper Retaining Head	25	HD	Thread-On	Brass	A/C	Standard thread on robotic retaining head
404-71	Diffuser	25	HD	Thread-On	Copper	W/C	Diffuser for 600 amp TOUGH GUN Robotic Water-Cooled MIG Gun

## Retaining Heads/Diffusers - For Semi-Automatic Applications

Part Number	Description	Qty	Duty	Nozzle Type	Material	Platform	Notes
154-14	Retaining Head	25	SD	Slip-On	Brass	A/C	Single Taper SD retaining head used on 18 amp TGX Guns
404-14-25	Retaining Head	25	SD	Slip-On	Brass	A/C	Single taper SD retaining head
404-20*	Retaining Head	100	HD	Slip-On	Brass	A/C	Single taper HD retaining head
404-26*	Dual Taper Retaining Head	100	HD	Slip-On	Brass	A/C	Standard dual taper retaining head
404-38-25	Diffuser	25	HD	Thread-On	Copper	W/C	Used on 62 & 64 series guns with 601 series nozzles & 601-5-75-3 ceramic insulator
404-44*	Retaining Head	100	HD	Slip-On	Brass	A/C	Bernard legacy neck conversion retaining head
404-53-25	Dual Taper Retaining Head	25	HD	Thread-On	Brass	A/C	Standard thread on semi-automatic retaining head

\* Other quantities available, contact Customer Service for more information.  
 Note: Air-Cooled (A/C) and Water-Cooled (W/C)

# TOUGH LOCK® Contact Tips

## Standard Duty (SD) Tips

0.250" Outside Diameter (O.D.)		Qty
403-14-23-25	for 0.023" (0.6 mm)	25
403-14-30*	for 0.030" (0.8 mm)	100
403-14-35*	for 0.035" (0.9 mm)	100
403-14-1.0*	for 0.040" (1.0 mm)	100

## SD Tapered Tips (0.250" O.D.)

403-12-30-25	for 0.030" (0.8 mm)	25
403-12-35-25	for 0.035" (0.9 mm)	25
403-12-45-25	for 0.045" (1.2 mm)	25
403-12-52-25	for 0.052" (1.4 mm)	25

## Extended Life Tips (0.310" O.D.) (Chrome Zirconium)

403-27-30*	for 0.030" (0.8 mm)	100
403-27-35*	for 0.035" (0.9 mm)	100
403-27-1.0*	for 0.040" (1.0 mm)	100
403-27-45*	for 0.045" (1.2 mm)	100
403-27-364*	for 3/64" (1.2 mm)	100
403-27-52*	for 0.052" (1.3mm)	100

## Heavy Duty (HD) Tips (0.310" O.D.)

Qty	
403-20-30*	for 0.030" (0.8 mm) 100
403-20-35*	for 0.035" (0.9 mm) 100
403-20-1.0*	for 0.040" (1.0 mm) 100
403-20-45*	for 0.045" (1.2 mm) 100
403-20-364*	for 3/64" (1.2 mm) 100
403-20-52*	for 0.052" (1.3 mm) 100
403-20-1.4*	for 0.055" (1.4 mm) 100
403-20-116*	for 1/16" (1.6 mm) 100
403-20-1.8*	for 0.070" (1.8 mm) 100
403-20-78*	for 0.078" (2.0 mm) 100
403-20-564*	for 5/64" (2.0 mm) 100
403-20-332*	for 3/32" (2.4 mm) 100

## HD Tapered Tips (0.310" O.D.)

403-21-30*	for 0.030" (0.8 mm)	100
403-21-35*	for 0.035" (0.9 mm)	100
403-21-1.0*	for 0.040" (1.0 mm)	100
403-21-45*	for 0.045" (1.2 mm)	100
403-21-52*	for 0.052" (1.3 mm)	100
403-21-116*	for 1/16" (1.6 mm)	100

## Extra Heavy Duty Tips (0.375" O.D.)

Qty	
603-20-1.0-25	for 0.040" (1.0 mm) 25
603-20-45-25	for 0.045" (1.2 mm) 25
603-20-364-25	for 3/64" (1.2 mm) 25
603-20-52-25	for 0.052" (1.3 mm) 25
603-20-1.4-25	for 0.055" (1.4 mm) 25
603-20-116-25	for 1/16" (1.6 mm) 25
603-20-564-25	for 5/64" (2.0 mm) 25
603-20-332-25	for 3/32" (2.4 mm) 25
603-20-764-25	for 7/64" (2.8 mm) 25
603-20-18-25	for 1/8" (3.2 mm) 25

## TOUGH LOCK Teach Tips (0.310" O.D.) (for robotic programming)

403-20-01	Adjustable Teach Tip	1
403-20-05	Teach Tip, 1/2"	1
403-20-062	Teach Tip, 5/8"	1
403-20-075	Teach Tip, 3/4"	1
403-20-10mm	Teach Tip, 10 mm	1
403-20-15mm	Teach Tip, 15 mm	1

## TOUGH LOCK Tip Tool

450-18	Tip Tool	1
--------	----------	---

NOTE: Torque to 30 in.-lbs. (3.5 Nm)

\*Other quantities available, contact Customer Service for more information.

# Nozzles

## Tregaskiss Nozzles feature:

- High-temperature resistant fiberglass insulators electrically insulate the nozzle from the diffuser
- Heavy duty crimp holds all three layers together
- Available in slip-on and thread-on styles



Bottleneck



Straight



Taper

## Light Duty Air-Cooled Nozzles (Slip-On)

For use with TOUGH LOCK® Diffuser 154-14

Part Number	Bore	Tip Placement	Type	Material	O.D.	Length	Qty
151-1-38	3/8"	1/8" Recess	Taper	Brass	0.813"	2.13"	10
151-1-50	1/2"	1/8" Recess	Taper	Brass	0.813"	2.13"	10
151-50	1/2"	Flush	Taper	Brass	0.813"	2.00"	10

## Nozzles (Continued)

### Standard Duty (SD) Air-Cooled Nozzles (Slip-On)

For use with TOUGH LOCK® Diffuser 404-32 (Robotic) or 404-26 (Semi-Automatic)

Part Number	Bore	Tip Placement	Type	Material	O.D.	Length	Qty	Reamer Cutter Blade
401-40-38	3/8"	1/16" Recess	Taper	Brass	0.978"	2.81"	10	---
401-42-50**	1/2"	1/8" Recess	Bottleneck*	Brass	0.938"	2.88"	10	RCT-04
401-4-38	3/8"	Flush	Taper	Copper	0.938"	2.74"	10	---
401-44-50	1/2"	1/4" Stick-out	Bottleneck*	Brass	0.938"	2.50"	10	RCT-04
401-44-62	5/8"	1/4" Stick-out	Taper	Copper	0.938"	2.51"	10	RCT-01
401-4-50**	1/2"	1/8" Recess	Taper	Copper	0.938"	2.88"	10	RCT-04
401-4-62**	5/8"	1/8" Recess	Taper	Copper	0.938"	2.88"	10	RCT-01
401-4-75	3/4"	1/8" Recess	Straight	Copper	0.938"	2.88"	10	RC-12
401-48-50	1/2"	1/8" Stick-out	Bottleneck*	Brass	0.938"	2.63"	10	RCT-04
401-8-62	5/8"	1/8" Stick-out	Taper	Copper	0.938"	2.63"	10	RCT-01

\*Straight bore; ideal for reaming

\*\*Available in quantities of 2 by adding -02 to the end of the Part Number ie. 401-42-50-02

### Standard Duty Air-Cooled Nozzles (Thread-On)

For use with TOUGH LOCK® Diffuser 404-52 (Robotic) or 404-53 (Semi-Automatic)

Part Number	Bore	Tip Placement	Type	Material	O.D.	Length	Qty	Reamer Cutter Blade
401-18-62	5/8"	1/8" Stick-out	Taper	Copper	0.938"	2.63"	10	RCT-01
401-42-38	3/8"	1/8" Recess	Taper	Copper	0.938"	2.88"	10	---
401-43-50	1/2"	1/4" Recess	Taper	Copper	0.938"	3.00"	10	RCT-04
401-43-62	5/8"	1/8" Recess	Taper	Copper	0.938"	2.88"	10	RCT-01
401-47-51	1/2"	1/8" Recess	Taper	Copper	0.938"	2.88"	10	RCT-04
401-48-50CT	1/2"	1/8" Stick-out	Taper	Copper	0.938"	2.63"	10	RCT-04

### Heavy Duty (HD) Air-Cooled Nozzles (Slip-On)

For use with TOUGH LOCK® Diffuser 404-32 (Robotic) or 404-26 (Semi-Automatic)

Part Number	Bore	Tip Placement	Type	Material	O.D.	Length	Qty	Reamer Cutter Blade
401-48-62	5/8"	Flush	Bottleneck*	Copper	1.062"	2.76"	10	RCT-01
401-49-62	5/8"	1/8" Stick-out	Bottleneck*	Copper	1.062"	2.63"	10	RCT-01
401-50-62	5/8"	5 mm Recess	Bottleneck*	Copper	1.062"	2.95"	10	RCT-01
401-51-62	5/8"	Flush	Bottleneck*	Brass	1.062"	2.76"	10	RCT-01
401-5-62**	5/8"	1/4" Recess	Taper	Copper	1.062"	3.00"	10	RCT-01
401-5-75	3/4"	1/4" Recess	Taper	Copper	1.062"	3.00"	10	RC-12
401-6-50	1/2"	1/8" Recess	Taper	Copper	1.062"	2.88"	10	RCT-04
401-6-62**	5/8"	1/8" Recess	Taper	Copper	1.062"	2.88"	10	RCT-01
401-6-75	3/4"	1/8" Recess	Taper	Copper	1.062"	2.88"	10	RC-12
401-71-62	5/8"	1/8" Recess	Taper*	Brass	1.106"	2.88"	10	RCT-01
401-72-62	5/8"	1/8" Recess	Taper	Brass	1.062"	2.88"	10	RCT-01
401-7-62	5/8"	1/4" Recess	Taper	Brass	1.106"	3.00"	10	RCT-01
401-7-75	3/4"	1/8" Recess	Taper	Brass	1.106"	2.88"	10	RC-12
401-7-87	7/8"	1/4" Recess	Straight	Brass	1.106"	3.00"	10	RC-12***
401-81-62	5/8"	1/8" Stick-out	Taper	Copper	1.062"	2.63"	10	RCT-01
401-87-56	9/16"	1/8" Recess	Taper	Brass	1.062"	2.88"	10	RCT-04***
401-87-62	5/8"	1/8" Stick-out	Taper	Brass	1.062"	2.63"	10	RCT-01
401-88-62	5/8"	Flush	Taper	Brass	1.062"	2.76"	10	RCT-01
401-91-62	5/8"	1/8" Stick-out	Taper*	Brass	1.106"	2.63"	10	RCT-01
401-92-62	5/8"	1/4" Stick-out	Taper	Brass	1.106"	2.50"	10	RCT-01

\*Straight bore; ideal for reaming

\*\*Available in quantities of 2 by adding -02 to the end of the Part Number ie. 401-50-62-02

\*\*\*May not clean spatter ring inside nozzle bore

## Nozzles (Continued)

### Heavy Duty Air-Cooled Nozzles (Thread-On)

For use with **TOUGH LOCK Diffuser 404-52 (Robotic) or 404-53 (Semi-Automatic)**

Part Number	Bore	Tip Placement	Type	Material	O.D.	Length	Qty	Reamer Cutter Blade
401-14-62	5/8"	1/8" Recess	Taper	Copper	1.062"	2.88"	10	RCT-01
401-19-62	5/8"	1/4" Recess	Taper	Brass	1.062"	3.00"	10	RCT-01
401-20-62	5/8"	1/8" Stick-out	Taper	Copper	1.062"	2.63"	10	RCT-01
401-41-62	5/8"	1/8" Stick-out	Taper	Brass	1.062"	2.63"	10	RCT-01
401-53-62	5/8"	1/8" Stick-out	Bottleneck	Copper	1.062"	2.63"	10	RCT-01
401-52-62	5/8"	1/4" Recess	Taper	Copper	1.062"	3.00"	10	RCT-01

### Heavy Duty Water-Cooled Nozzles

For use with **600 amp T-Gun™ Water-Cooled and TOUGH GUN Automatic Water-Cooled MIG Guns**

Part Number	Bore	Tip Placement	Type	Material	O.D.	Length	Qty	Reamer Cutter Blade
601-5-62	5/8"	1/4" Recess	Taper	Nickel-Plated Bronze	1.225"	3.13"	10	RCT-01
601-6-62	5/8"	1/8" Recess	Taper	Nickel-Plated Bronze	1.225"	3.00"	10	RCT-01
601-5-75	3/4"	1/4" Recess	Taper	Nickel-Plated Bronze	1.225"	3.13"	10	RC-12
601-6-75	3/4"	1/8" Recess	Taper	Nickel-Plated Bronze	1.225"	3.00"	10	RC-12

Use 601-5-75-3 insulator for all 601 Series Nozzles

Use 404-38 diffuser for all 601 Series Nozzles

### Heavy Duty Nozzles for TOUGH GUN Robotic Water-Cooled MIG Guns

Part Number	Bore	Tip Placement	Type	Material	O.D.	Length	Qty	Reamer Cutter Blade
650-6-62	5/8"	1/8" Recess	Taper	Chrome	1.062"	3.60"	2	RCT-01
650-6-75	3/4"	1/8" Recess	Taper	Chrome	1.062"	3.60"	2	RC-12

Use 404-32 Diffuser for all 650 Series Nozzles

## TOUGH LOCK Conversion Series

Add our TOUGH LOCK Consumables, durable nozzles and neck insulators / adaptors to your Bernard®, Binzel®, Lincoln® and Tweco® style MIG Guns. Find your MIG gun make and model on the left, then follow the chart to the right for parts needed to upgrade.

**\*NOTE:** The 404-20 TOUGH LOCK Retaining Head will fit on most necks with an external 9/16"-18 thread regardless of angle.

Gun Manufacturer	Gun Model	Gun Neck	TOUGH LOCK Heavy Duty Retaining Head	Neck Insulator	Adaptor
Bernard™	Q-Gun™ Series	Legacy Neck	404-44	4423R	N/A
Binzel®	ALPHA 4	---	404-46	402-11	N/A
Lincoln®	Magnum® 300	KP1929 / KP1928 / KP1941	404-20*	4423R	N/A
	Magnum® 400	KP1929 / KP1928 / KP1941	404-20*	4423R	N/A
Tweco®	Tweco #3	63J-60	404-20*	4423R	N/A
	Tweco #4	64J-60	404-20*	4423R	N/A
	Spray Master™ 350	MS63-60	404-20*	4423R	N/A
	Spray Master™ 450	MS64H-60	404-20*	4423R	N/A
	WeldSkill® 400	64A-60	404-20*	4423R	N/A
	MINI-MIG	---	N/A	402-19	404-64

Tregaskiss®, TOUGH GUN®, TOUGH LOCK®, QUICK LOAD® and AutoLength™ are trademarks of Tregaskiss, a division of ITW Canada Inc. Bernard®, Miller®, and T-Gun™ are trademarks of Illinois Tool Works, Inc. Other brands mentioned are for reference only and are the registered trademarks of their respective companies. Illinois Tool Works, Inc. is not affiliated with these other companies.

Subject to Change – The information presented in this spec sheet is accurate to the best of our knowledge at the time of printing. Please visit [Tregaskiss.com](http://Tregaskiss.com) for the most up-to-date information.

Distributed By:

